Acoustics and Experimental Methods: The Influence of Sound on Flow and Heat Transfer

M. C. Welsh
K. Hourigan
L. W. Welch
R. J. Downie
M. C. Thompson
A. N. Stokes

Commonwealth Scientific and Industrial
Research Organisation,
Melbourne, Victoria, Australia

■ The influence of sound on the type of experimental methods used in flow and heat transfer test rigs is discussed. The type of acoustic mode that interacts most readily with the flow is described. When solid walls are present in the working section of test rigs and wind tunnels, acoustic modes can readily be excited in the working sections without the knowledge of experimenters and can lead to an erroneous interpretation of test results. Examples of the interaction between loud sounds, up to 150 dB, and the flow are described. These sounds can be generated by the flow, but in general they are easily detected since they are heard by the experimenter and alter the flow and the heat transfer characteristics in a very obvious manner. Recent experiments at CSIRO show that sound levels between 70 and 95 dB (with corresponding ratios of the velocity due to sound to the freestream velocity of between ~ 0.0001 and ~ 0.002) generated by the flow can alter both the flow and the heat transfer characteristics in a manner not immediately obvious to the experimenter. Consequently, a microphone should always be located in the working section of a wind tunnel with the test model installed so that unwanted sound can be detected. Methods of canceling the unwanted sound in wind tunnels and test rigs are also presented.

Keywords: *measurement techniques, acoustics, sound and flow, sound and heat transfer, separated flow*

INTRODUCTION

The earliest report of the influence of sound on shear layers is that by Leconte [1] in 1858 where he describes the jumping of a coal flame in response to certain notes of a violoncello. During this period, Tyndall [2] also showed that the character of flames was altered radically by the influence of sound. He observed that the changes were a function of the frequency of the sound and, more important, that it was necessary to apply the sound at the seat of the flame (ie, where the shear layer is separating from a solid surface) for the interaction between the flame and the sound to occur. Tyndall [2] also showed that jets without combustion were sensitive to sound, and in 1884 Rayleigh [3] extended this study using resonators.

Batchelor [4] studied sound in wind tunnels in 1945 with a view to reducing the sound levels in the working sections to a satisfactory level for turbulence studies. He was clearly aware of the interactions between sound and turbulence, and together with Townsend [5] studied the excitation of sound in the turning vanes of a wind tunnel at the University of Sydney.

Parker [6, 7] in the 1960s described the excitation of resonant sound by the flow around cascades of flat plates. In this work, he clearly established the existence of transverse duct acoustic modes, which are readily excited by the flow and defined the shapes of the simpler modes as α , β , γ , and δ . The mode relevant to the present paper, the β mode, is shown

in Fig. 1. It is essentially a standing wave with maximum acoustic pressures at midchord midway between the plates and zero acoustic pressures in the horizontal planes containing each plate in the cascade. On each plate surface, the acoustic particle velocities are parallel to the surface and become zero at midchord. Away from the plates in both the upstream and downstream directions, the acoustic particle velocities of the β mode are predominantly transverse to the duct and decay exponentially with distance.

Parker also showed that the resonant sound was excited when the natural Strouhal vortex shedding frequency from the trailing edge of the flat plates was near the acoustic resonant mode frequency. The resonant sound "fed back" onto the shear layers separating from the trailing edges and correlated the vortex shedding with the sound field. This increased the amount of energy transferred from the flow to excite the sound field.

Bechert [8] presented a very clear review of recent work on the artificial excitation of instability waves in shear flows. He pointed out that convectively unstable flows, such as boundary layers and free shear layers, depend on a supply of energy to maintain excitation of the instability. The mechanism by which the sound field enhances the instabilities is not completely understood, but clearly, for boundary layers, the Tollmien-Schlichting waves play an important role.

In recent years, the role of large-scale coherent vortex struc-

Address correspondence to Mrs. C. Bowditch, Editorial Officer, CSIRO Division of Building Construction and Engineering, P.O. Box 56, Highett 3190, Melbourne, Victoria, Australia.

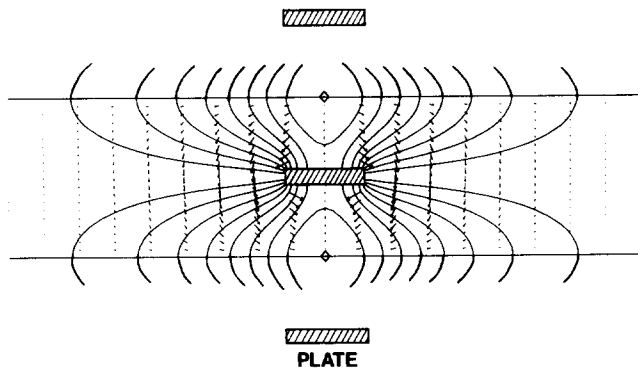

Figure 1. The acoustic β mode for rectangular plates mounted in a duct. Arrows show local direction and magnitude of the acoustic particle velocities; curved solid lines show isobars; \diamond , maximum RMS acoustic pressure.

tures has been prominent in the literature describing shear layers, and there are many papers that review the subject [9–11 and others]. There are also many other papers that report studies of coherent structures, in particular separated flows. For example, Brown and Roshko [12] identified the large-scale structures in a mixing layer, while Perry et al [13] studied the coherent structures in jets and wakes, and Perry and Chong [14] applied analytical techniques to the study of such flows. Hussain [15] also published a very lucid review describing coherent structures and turbulence. In that article, Hussain refers to the *education process* that can be used to identify the role played by coherent structures in generating the observed characteristics of separated flows.

In early education schemes, the coherent structures in separated flows were educated by superimposing sound on the flow using loud speakers. Hussain and Zaman [16] educated coherent structures at different phases during pairing in a jet by imposing sound in the flow settling chamber upstream of the jet exit. They were able to educate the preferred mode structure in the near field of an axisymmetric jet [17]. In this case, low-level sound was applied to the flow; that is, the velocity perturbations caused by the sound were not greater than one-thousandth of the mean jet exit velocity ($u'/U \leq 0.001$). Zaman and Hussain [18] showed later that these low-level perturbations triggered the formation of only the most unstable mode in the jet and therefore merely regulated the initiation of the structures that occur naturally.

As alluded to in Ref. 15 and shown in Ref. 18, when the sound level is high (sound perturbation velocity $u' \leq 0.02$ times the mean flow velocity U), the associated perturbation *modifies* the structures in the flow and can significantly alter subsequent interactions between structures. Such interactions are of interest both scientifically and technologically.

The aim of this paper is to emphasize the need for experimenters to be well aware of the influence of sound on the flows in their test rigs. A description of the influence of the sound observed by a number of experimenters is given to illustrate how flow and sound interact. This includes experiments undertaken in our laboratory, where large perturbations due to sound are superimposed on separated flows and boundary layers. Two methods of imposing the sound will be discussed: (1) sound is produced by speakers strategically located above and below the flow in open jet wind tunnels, and (2) resonant sound is generated by the flow and reflects back onto the flow (feedback) from the walls of the wind tunnel. For both cases, the sound changes the flow structure.

Experiments currently being undertaken in our laboratory will then be described where sound pressure levels (SPLs) from 70 to 111 dB at the transverse resonant acoustic β -mode frequency are generated by the flow. It will be shown that sound in the low-level range (70–95 dB; $0.0001 \leq u'/U \leq 0.002$) can also alter the flow, and because of its low level the change could occur without the knowledge of the experimenter. Possible methods for canceling the unwanted sound will be presented, while techniques for predicting the feedback effect of the sound on the flows will be discussed. Technological applications of this work will be presented.

EXAMPLES OF EXPERIMENTS IN WHICH LOUD SOUND, GENERATED BY SPEAKERS, CHANGES THE FLOW BEHAVIOR

There are many examples in the literature of changing separated flows with loud sound. Some of the more technologically relevant cases are discussed below.

Peterka and Richardson [19] subjected the flow around a circular cylinder to a transverse standing sound wave generated by loud speakers. They found that the formation region of the vortex street reduced in size when the sound was applied, and the rate of heat transfer from the surface of the cylinder near separated flow increased. Sound levels up to 140 dB were applied at frequencies close to those occurring naturally in the shear layers. Peterka and Richardson [19] concluded that the changes to the flow with the sound applied were due to vortex fusion and possibly vortex breakdown.

Archibald [20] subjected the flow around a thick plate with a semicircular leading edge to loud sound up to 140 dB when the plate was located inside a duct. He studied the phase relationships between the flow and acoustic pressures and was able to change the Strouhal number of the vortex shedding from the trailing edge of the plate by $\pm 20\%$.

Bhattacharjee et al [21] perturbed a shear layer separating from the corner of a backward-facing step with a sound field generated by a loud speaker. The amplitude of the sound field at the step edge was 92 dB. They found that when the forcing frequency was less than the frequency of the broad spectral peak that occurs in the signal from a hot wire located in the shear layer, the growth of large-scale vortices passing the hot wire is preferentially enhanced at the forcing frequency. There was a significant decrease in the reattachment length accompanied by an increased rate at which the shear layer thickened. When the forcing frequency of the sound was greater than the frequency of the broad spectral peak in the absence of loud sound, there was little or no effect on the spectrum of the hot-wire signal. The implication is that when sound was applied at the higher frequency it did not change the growth rate of vortices in the shear layer.

Parker and Welsh [22] studied the response of shear layers separating from the sharp corners of thick plates with a square leading edge in the presence of a transverse sound field. Each plate was located in the working section of an open jet wind tunnel between two speakers located just above and below the jet. Sound was applied over a range of frequencies at levels up to 126 dB at the midchord position on the surface of the plate. The frequencies of the applied sound were always much less than the most unstable frequencies occurring naturally in the shear layers in the absence of sound near the point of separation [23, 24] and greater than the large-scale vortex shedding frequency from the leading edge separation bubble. Using stroboscopic light to illuminate smoke flowing around

the plate, the position on each side of the plate where the shear layer reattached was seen to oscillate along the plate surface at the forcing frequency. As was the case for the backward-facing step [21], the mean reattachment length was reduced appreciably when sound was applied.

At the high sound levels, with the velocity perturbation one-fourth of the upstream mean flow velocity, the oscillating position of reattachment was associated with a large-scale vortex being shed from the leading edge separation bubble into the flow on each side of the plate. This occurred during each acoustic cycle and produced a chain of vortices distributed regularly along the surfaces of the plate.

Parker and Welsh [22] also studied the effect of sound on the vortex street shed from the trailing edge of plates with square leading edges. When the chord-to-thickness ratio was between 3.2 and 7.6, regular vortex streets were shed without forcing. However, when sound was applied at twice the natural vortex shedding Strouhal number at levels ≥ 122 dB, the vortex street was "locked" to the sound field and vortices shed at the acoustic Strouhal number. For plates with chord-to-thickness ratios of between 7.6 and 16, regular vortex streets were not shed under normal flow conditions, but when loud sound was applied, regular vortex streets were shed at the forcing frequency for acoustic Strouhal numbers ranging from 0.05 to 0.21. Outside this range the vortex streets were still shed but were unstable.

The effect of sound on the heat transfer from a rectangular plate with an electrically heated stainless steel strip embedded in its surface was investigated in the experiments of Cooper et al [25]. They showed that the local surface heat transfer coefficient where the flow reattached increased significantly when sound was applied. The overall heat transfer coefficient at the plate surface was also increased with the application of sound. These studies were extended by Hourigan et al [26], who used Schlieren techniques to record instantaneous fluid density gradients surrounding the plate and employed mathematical models and laser doppler anemometry to determine the instantaneous fluid motion. They showed that the instantaneous local surface heat transfer coefficient was enhanced in the region immediately downstream of large-scale vortex structures due to increased movement of fluid from the cooler freestream toward the heated surface. Cooper et al [25] also showed that the aerodynamic drag on the plate increased when sound was applied.

Summarizing, the experiments described above show that loud transverse sound fields superimposed on flows separating from blunt bodies installed in wind tunnels enhance those instabilities in the shear layers that have natural frequencies coinciding with the forcing frequency. Large-scale vortex structures then develop at the forcing frequency and dominate the boundary layer flow, leading to increases in both the overall heat transfer coefficient and the aerodynamic drag.

EXPERIMENTS IN WHICH LOUD SOUND, GENERATED BY FLOW IN A DUCT, FEEDS BACK AND CHANGES THE FLOW BEHAVIOR

There are an increasing number of reports describing the excitation of loud sound by flows and how the sound changes the flow behavior. Some of the more detailed studies are described below.

According to the theory of aerodynamic sound put forward by Howe [27], maximum instantaneous acoustic power is gen-

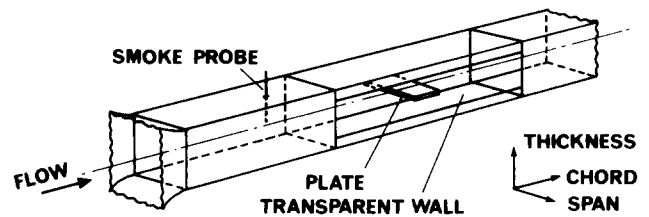

Figure 2. Sketch of the working section with a plate installed.

erated by a vortex when the direction of its motion is perpendicular to the local acoustic particle velocity of the sound field. Maximum net acoustic power over a sound cycle is generated in regions of the flow where the angle between the vortex velocity and the local acoustic particle velocity is markedly different in one half of an acoustic cycle compared with that in the next half cycle; this can occur near edges of a blunt body where acoustic particle velocities are forced to follow the contour of the body, whereas the vortex can move in a direction with a component normal to the body surface.

Welsh and Gibson [28] studied a case analogous to that studied by Parker [6, 7] but used a plate that had a square leading edge (as opposed to one that was streamlined) located in a duct where the side walls coincided with the horizontal planes midway between the plates in the vertical cascade (Figs. 1 and 2). Even though the shear layers separated from the leading edge corners (instead of the trailing edge as observed on a streamlined plate), resonant sound was still excited when the frequency of the vortex shedding downstream of the trailing edge was near the resonant acoustic frequency. The sound fed back onto the shear layers and synchronized the vortex shedding near the trailing edge with the sound field. Welsh and Gibson [28] also found that when the natural Strouhal vortex shedding frequency was approximately half the resonant acoustic frequency (ie, the flow velocity was half that at which resonance was normally excited), the same resonant acoustic β mode at the same frequency was again excited. Initially the amplitude of the sound was low, but it fed back onto the shear layers separating from the leading edge, causing reattachment closer to the leading edge. In turn, a vortex was shed from the shortened separation bubble on each side of the plate once during each acoustic cycle. After being shed, the vortices moved along the plate and past the trailing edge to form a vortex street with a Strouhal number twice that of the natural vortex shedding Strouhal number occurring in the absence of sound.

Nomoto and Culick [29] described the case of flow over two pairs of baffle plates in a square duct (Fig. 3) that excited

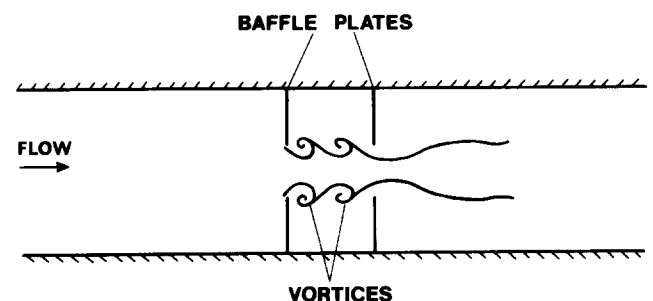

Figure 3. Sketch of the working section with baffles installed in a square duct and vortices being shed from the upstream baffle.

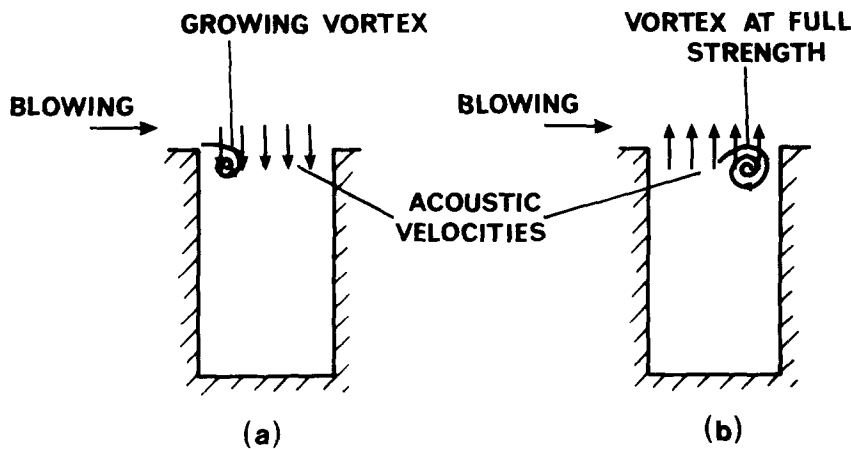

Figure 4. Sketch of a vortex crossing the acoustic field in a Helmholtz resonator.

the organ pipe modes of the duct. The pairs of baffles were arranged with one extending down from the top wall while the other extended up from the bottom wall, leaving an opening of 25% of the duct cross-sectional area. Loud resonant sound caused large-scale vortices to shed in phase from each baffle in the upstream set at the sound frequency. This feedback effect produced two rows of vortices between the sets of baffles similar to a thrust vortex street [30]. In addition, vortices with opposite-sign vorticity moved in pairs, since they were shed at the same instant and not half a cycle apart as is the case for more conventional drag vortex streets (Fig. 3). Nelson et al [31] studied the flow moving across the opening of a Helmholtz resonator generating loud resonant sound (Fig. 4). The resonating sound field caused fluid to oscillate in and out of the resonator tube and to perturb the shear layer separating from the upstream edge of the cavity opening. This feedback effect caused the shear layer to roll up into large vortex structures. One vortex was formed and traversed the width of the opening of the resonator tube during each acoustic cycle (Fig. 4).

Kawahashi et al [32] examined the flow shedding from a rod with a triangular cross section (wedge) into a Hartmann-type resonator tube (Fig. 5). Without resonant sound, vortices were shed alternately from the corners of the wedge in a manner similar to the shedding from circular cylinders, thick plates, etc. However, at particular flow velocities, loud sound was generated with a wavelength related to the length of the resonator tube. The acoustic particle velocities imposed a perturbation on the shear layer separating from each leading corner of the wedge (Fig. 5). The perturbation occurred simultaneously at each shedding point (corner), and consequently the vortices shed simultaneously from each side of the wedge. The result was a vortex street with vortices distributed in pairs along the street.

Parker and Stoneman [33, 34] extended their studies of the

acoustic resonant process to models of high technology axial flow compressors. The feedback effect of the sound was again observed to cause vortex shedding over wide ranges of Strouhal number.

Summarizing, when loud sound is generated by the flow and reflected back from the side walls of a duct onto the flow, it changes the flow behavior as if the sound had been generated by loud speakers. The result in both cases is that those instabilities in the shear layers corresponding to the forcing sound frequency are enhanced and large-scale vortex structures are generated at the frequency of the sound. The vortices are seen to commence growth at a phase of the sound cycle where the acoustic particle velocity at the point of flow separation begins to augment the mean flow velocity.

For flow-induced acoustic resonances associated with cavities and ducts, the large-scale vortex structures generated in the shear layers must be in specific regions of the flow at particular times in the acoustic cycle for there to be a net transfer of energy from the flow to sustain the sound. This aspect of the acoustic resonant process is explained in detail in Refs. 35 and 36 and will not be further addressed in this paper.

Sound generated by flow around blunt bodies not located in ducts has been examined in detail by Rockwell [37], Rockwell and Naudascher [38], Johnson and Loehrke [39], Mochizuki et al [40], and others and will also not be described in this paper.

EXPERIMENTAL EQUIPMENT AND PROCEDURES USED IN THE RESEARCH PROGRAM AT CSIRO

General

Five experimental test rigs, shown in Figs. 6–9, are used to study the influence of sound on separated flow in our laboratory experiments. The cross sections of the working section

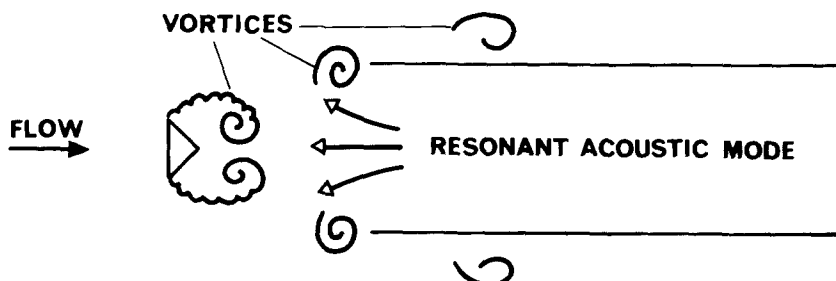

Figure 5. Sketch of a wedge shredding vortices symmetrically in the presence of a resonant acoustic mode of a resonator tube.

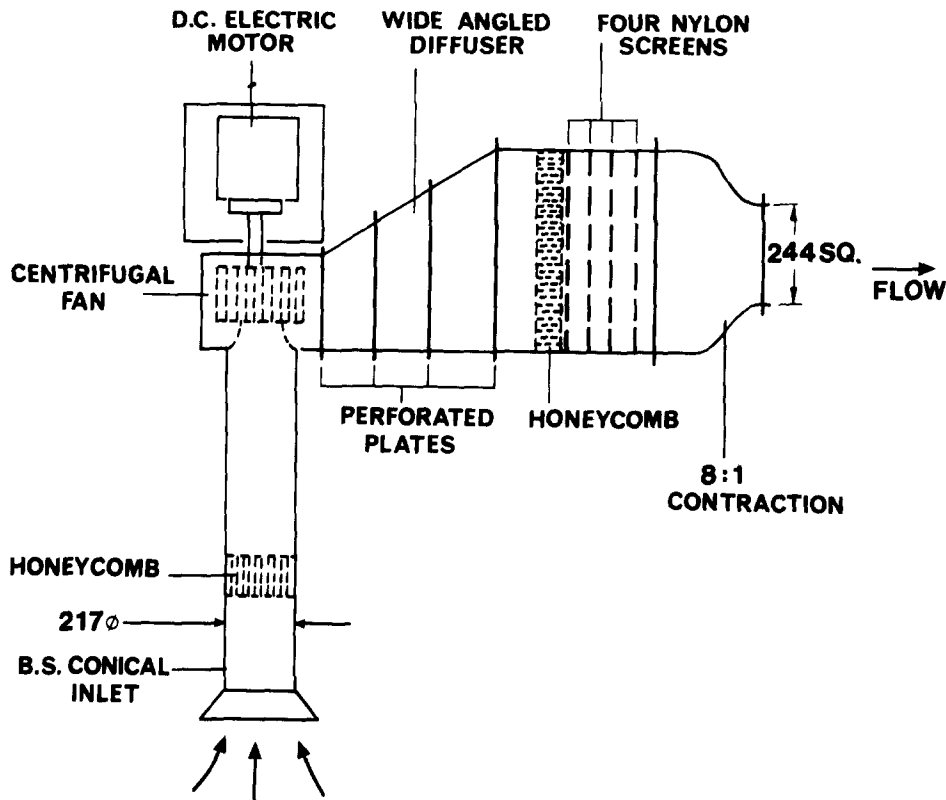

Figure 6. Schematic of an open jet wind tunnel (working section shown in Fig. 7).

of the wind tunnels and the water tunnel are standardized at 244 mm square. Other components of the tunnels, such as the contractions of the air tunnels, also have similar inlet and outlet dimensions. This permits maximum flexibility with the assembly of test rigs.

Open Jet Wind Tunnels

The test rig illustrated in Fig. 6 is an open jet wind tunnel where the air is supplied by a centrifugal fan powered by a variable-speed motor. Flow from the fan is directed through a diffuser to a settling chamber containing screens and a honeycomb. The air then passes through an 8-to-1 contraction to form an open jet with an outlet that is 244 mm square. This rig is described in detail in Refs. 22 and 26. The boundary layers at the jet exit are approximately 5 mm thick, and the velocity in the core of the jet is uniform within $\pm 0.5\%$. The maximum velocity on the centerline is 15 m/s, and the longitudinal turbulence intensity in the core is 0.3% with measurable spectral content less than 150 Hz. A second open jet wind tunnel is obtained by fitting a larger fan to the settling chamber. The maximum velocity in the working section of this tunnel is 30 m/s.

Test models (thick flat plates) are located in the jet at the outlet of the contraction, and a standing wave is superimposed on the flow by means of two speakers located above and below the jet (Fig. 7). The speakers are connected in antiphase, and their respective amplitudes are adjusted to give an acoustic pressure node in the plane containing the plate. Without a model installed, the acoustic particle velocities are everywhere transverse to the mean flow direction. With a plate installed, the modal shape is similar to a β mode in a duct (Fig. 1).

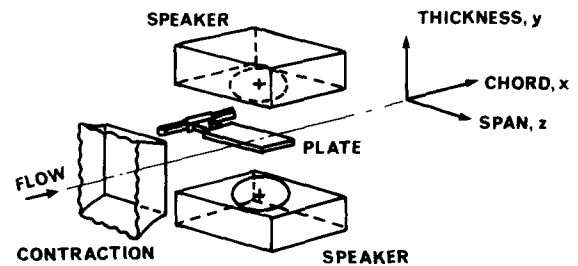

Figure 7. Schematic of the working section of an open jet wind tunnel with speakers and plate installed.

These test rigs were used by Parker and Welsh [22] for studying the feedback effect of loud sound on the flow during the flow-induced acoustic resonant process, and by Copper et al [25] and Hourigan et al [26] to study the instantaneous forced thermal convection process.

Open-Circuit Draw-Through Wind Tunnel

The test rig illustrated in Fig. 8 is an open-circuit wind tunnel used for flow-induced acoustic resonance studies. The air is drawn through the tunnel by a two-stage axial flow fan that is powered by a variable-speed motor with accurate speed control. Sound is generated by the flow and then feeds back by reflecting from the side walls to modify the flow state and sustain the maximum net transfer of energy from the flow to the sound field. The working section can be varied in length between 2.56 and 2.88 m. The walls are made from 50 or 25 mm thick acrylic and 12 mm thick aluminum to minimize their vibration during resonance. The ratio of the maximum acoustic particle velocity to the maximum measured wall vi-

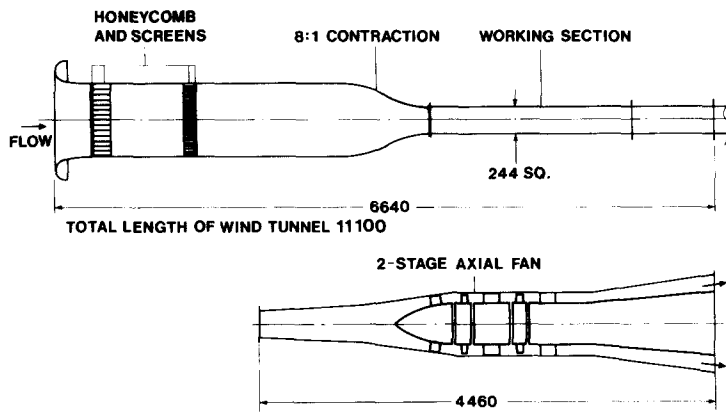

Figure 8. Schematic of the open-circuit draw-through wind tunnel.

bration velocity is 5×10^4 . Plates are located on the centerline of the working section with their longer sides parallel to the upstream direction. This test rig is described in detail in Refs. 28 and 35.

The velocity profile in the working section is uniform within $\pm 0.5\%$ between the wall boundary layers, which were approximately 20 mm thick, with no measurable spectral content greater than 150 Hz. A maximum mean flow velocity of 70 m/s is possible.

Open-Circuit Blow-Through Wind Tunnel

A fourth test rig is assembled by connecting the working section of the open-circuit draw-through wind tunnel, shown in Fig. 7, to the outlet of the open jet wind tunnels, shown in Fig. 6. This tunnel was used to study the resonant acoustic process excited by the flow over baffles (Fig. 3) using a geometry in the working section similar to that used by Nomoto and Culick [29].

Water Tunnel

The test rig shown in Fig. 9 is a return-circuit water tunnel designed using accepted principles for minimizing the freestream turbulence level in air tunnels [41, 42]. Water is pumped into a settling chamber containing filter material and a honeycomb

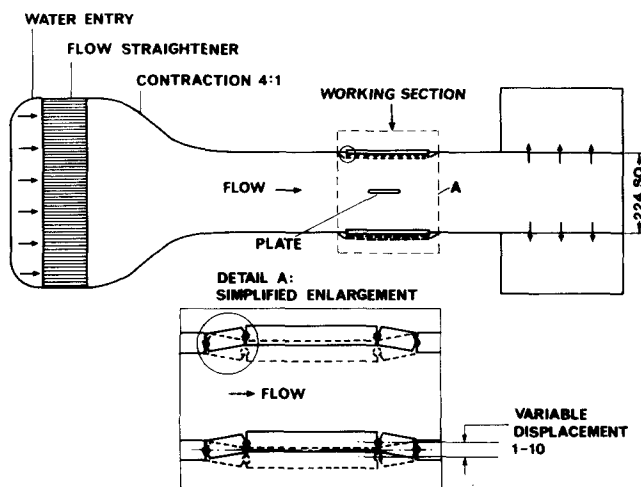

Figure 9. Schematic of the return circuit water tunnel showing the oscillating side walls of the working section.

and then passes through a two-dimensional 4-to-1 contraction before entering the working section. The working section is 770 mm long and is constructed from 25 mm thick acrylic supported in aluminum flanges.

The maximum mean flow velocity in the working section is 400 mm/s. Two panels in the side walls of the working section are rigidly connected to each other and are sealed to the remainder of the working section by a thin flexible membrane. This permits these side wall panels to be oscillated transverse to the mean upstream flow direction, thus superimposing a transverse flow velocity perturbation onto the flow. The oscillation of the sides walls can be varied from 0 to ± 5 mm at frequencies between 0 and 6 Hz. When a plate is located in the working section between the oscillating walls, a transverse flow velocity perturbation up to 150 mm/s can be imposed on the flow surrounding the body. For the experiments described in this paper, typical transverse wall displacements of 0.025 mm are imposed at 5.2 Hz on the flow, which has a mean velocity of 93.6 mm/s.

Flow Visualization, Instrumentation, and Procedures

Flow visualization in the air tunnels is achieved by introducing ammonia and sulfur dioxide gases separately into the flow to produce "smoke" using techniques developed by Bassett and Fowler [43]. These gases undergo an exothermic reaction to form ammonium sulfite powder, which clearly discloses flow patterns at flow velocities up to 70 m/s. Light is strobed over a range of frequencies and reflected onto the smoke by a system of mirrors to show the movement of flow patterns. Photographs of the flow are taken using a flash fired at predetermined points in an acoustic cycle. This technique is used to measure the phase relationship between the velocity perturbation imposed by the sound field and the instantaneous flow and thermal fields.

Flow visualization in the water tunnel is achieved using the hydrogen bubble technique [44, 45]. White light is used to illuminate the hydrogen bubbles, which are produced on a thin wire mounted on the surfaces of the plates. Video recordings and photographs of the flow around the plates are taken from above the tunnel or through the oscillating side walls (Fig. 9).

All the test rigs are connected on line to a PDP-11/44 computer with the capability of digitizing 32 channels of analog data at high speed using Interactive Laboratory Systems software. Laser doppler and hot-wire/film anemometry are used to measure the flow velocities, while Bruel and Kjaer microphones are used to measure the sound fields. Probe micro-

phones constructed from 1 mm O.D. hypodermic tubing are used in preference to 12.7 mm diameter Bruel and Kjaer microphones to give spatial resolution when examining the sound fields in the flow [36]. The signals from these microphones are corrected for both amplitude and phase distortion associated with standing waves in the hypodermic tubing by applying the transfer function between the probe microphone and a standard 12.7 mm diameter Bruel and Kjaer microphone. The vortex shedding and the β -mode resonant frequencies are determined using ninth-order fast Fourier transforms (FFT).

The SPLs at the acoustic β -mode resonant frequency and the frequency of vortex shedding from the trailing edge of the plates are determined from narrowband analysis (bin width of 3.125 Hz) of the probe microphone hot-wire signals. Since the microphone signals are tonal and up to 30 dB above the background, the amplitude of the spectral peak approximates the SPL at the required frequency. The amplitude of the spectral peak was calibrated using an input signal of known SPL from a Bruel and Kjaer piston phone.

RECENT FLOW-INDUCED ACOUSTIC RESONANCE EXPERIMENTS AT CSIRO

General

Experiments in which acoustic resonances were excited by the flow around a plate (or plates) in the working section were undertaken in the open-circuit wind tunnel shown in Fig. 8 and are described in Welsh et al [35], Stoneman et al [36], and Stokes and Welsh [46]. In each case, the interaction between flow and resonant sound was described for the excitation of the simplest transverse acoustic mode (ie, the β mode when one plate was installed in the duct, Fig. 1) or the analogous mode when two plates were installed in tandem in a duct. Although an infinite number of resonant transverse acoustic modes are possible in a duct containing a plate, the essential features of the flow-induced acoustic resonant process when transverse acoustic modes are involved are captured by studying the β -mode case.

When a plate is installed in a duct and the flow velocity is increased from zero, the frequency at which vortices shed from the trailing edge increases approximately linearly with flow velocity (constant Strouhal number). As the vortex shedding

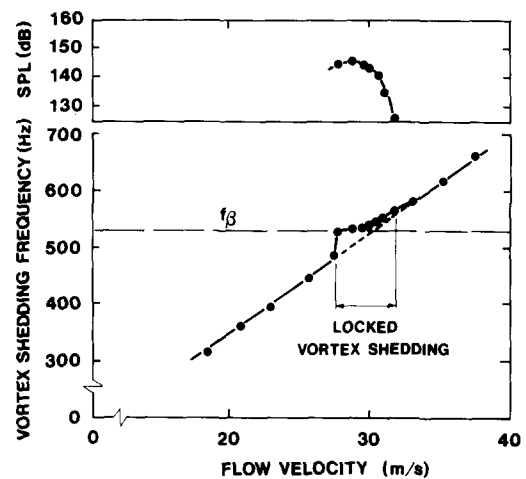

Figure 10. Plot showing the excitation of resonant sound and the locking of the vortex shedding for a plate with semicircular leading edge and square thick trailing edge, where $d = 12.1$ mm; Dashed line, β -mode resonant frequency (from Welsh et al [35]).

frequency approaches the β -mode resonant acoustic frequency (f_β) at approximately 30 m/s (Fig. 10), sound at the resonant frequency is excited, and the flow and the sound begin to interact to produce vortex shedding that is locked to the resonant acoustic frequency. If the plate has a semicircular leading edge, the feedback effect of the resonant sound is on the shear layers downstream of the trailing edge of the plate. The vortex shedding process becomes highly correlated across the span of the plate because the perturbation of the resonant acoustic field is effectively two-dimensional. A vortex street before and after being modified by this perturbation is shown in the flash exposures in Fig. 11. The "black holes" at the vortex centers in the clearly defined vortices during resonance are due to the removal of smoke by movement transverse to the mean flow (ie, into the page). With two plates located in tandem on the centerline of the working section, a resonance was generated that is analogous to the β mode [36]. The vortex street between the plates with feedback during resonance is shown in Fig. 12. This photograph was obtained by superimposing 20 exposures taken at the same instant in the sound cycle. Clearly

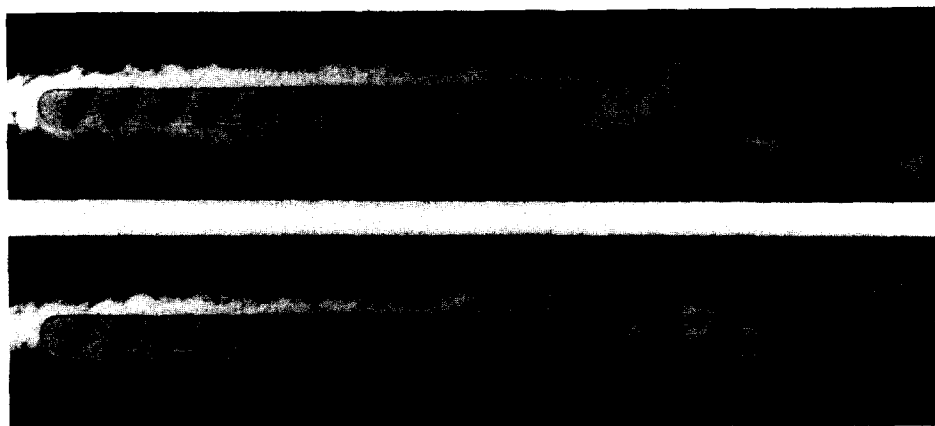

Figure 11. Photographs of the vortex streets shed from the square thick trailing edge of a semicircular leading edge plane (from Welsh et al [35]), $Re = 3 \times 10^5$; (a) without resonant sound, $St = 0.213$, $U = 24.6$ m/s; and (b) with feedback via a β -mode acoustic resonance, $SPL = 145.5$ dB, $St_\beta = 0.224$, $U = 29.0$ m/s.



Figure 12. Photograph of the vortex street around two plates with semicircular leading edge and trailing edge with feedback via an acoustic resonant mode analogous to the β mode (from Stoneman et al [36]), $U = 22.9$ m/s, SPL = 150 dB. Flow direction left to right.

the feedback effect of the sound stabilizes the vortex shedding process.

All of the data described in Refs. 35 and 36 demonstrate the excitation of resonant sound by the flow when the “natural” frequency of the vortex shedding from the trailing edge is near the resonant acoustic frequency (Fig. 10). Further studies by Stokes and Welsh [46] showed that when a plate with a square leading edge was installed in a duct, the same resonant acoustic β mode was excited. However, excitation of this β mode occurred over several ranges of flow velocity, and the resonant sound in each case was always at the same frequency. This was due to the feedback effect of the sound on the shear layers separating from the leading edge of the plate. The sound caused premature reattachment and caused a vortex to shed from the leading edge separation bubble into the boundary layer on each side of the plate once in each acoustic cycle (this process was similar to that described by Parker and Welsh [22] when sound was imposed using loud speakers in an open jet). Vortices were then shed from the trailing edge into the wake at the resonant acoustic frequency.

Low-Level Flow-Induced Sound Experiments

The experimental results referred to above relate to cases where loud sound is generated by the flow; the influence of the sound on the flow is significant and causes regular shedding of large-scale vortices. The presence of the sound is easily detected because it is loud (150 dB) and the flows are obviously different from those observed in the absence of loud sound (Fig. 11). Recent experiments at the CSIRO have extended the studies described above of acoustic resonance produced by flow around plates with semicircular leading edges. The results of these experiments show that, in addition to the loud resonance (150 dB), relatively low-level β -mode resonance sound (~ 70 –111 dB, $0.0001 \leq u'/U \leq 0.01$) can be excited by the flow at the same resonant frequency as that recorded for the loud resonance. For a typical case at these low levels (92 dB), resonance sound is excited and feeds back onto the flow near the leading edge of plates with semicircular leading edges to cause the regular shedding of vortices into the boundary layers.

The new experiments described here were undertaken in the open-circuit wind tunnel (Fig. 8) described above with the working section configured as shown in Fig. 13. A probe

microphone was located with its sensing hole 85.5 mm above the surface of the plate and 59.5 mm from the side wall in the midchord plane of the plate (yz plane in Fig. 7). Two hot-wire sensors were located in the midspan plane, one midchord and the other 30.9 mm downstream of the trailing edge. The sensor in the midchord plane was 10.2 mm above the surface of the plate, while the remaining hot-wire sensor was 10.7 mm above the centerline of the duct.

Three different plate geometries were tested, and these geometries are detailed in Table 1. One plate had a semicircular leading edge and a square thick trailing edge, with the upper and lower surfaces parallel to each other. This plate and a symmetric C4 airfoil (see Ref. 47 for the definition of a C4 airfoil) of similar chord and similar maximum thickness were split at 33% of their respective chords from their leading edges. Two new plates were then constructed by joining (1) the leading portion of a C4 airfoil with the remaining thick square portion of the plate and (2) the leading portion of the original plate with the trailing portion of the C4 airfoil.

All plates were located in both the air and water tunnels with their major axes of symmetry parallel to the upstream flow direction. The flow velocities were varied with corresponding Reynolds numbers (based on plate chord and upstream flow velocity) varying between 5×10^4 and 2×10^5 in the air tunnel.

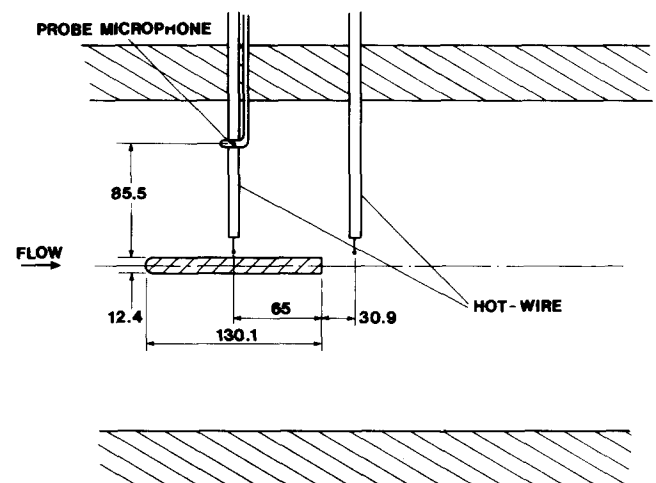

Figure 13. Schematic of the working section of the open circuit wind tunnel used for recent aeroacoustic studies.

Table 1. Dimensions of Plates

Leading Edge Shape	Trailing Edge Shape	Chord (mm)	Thickness (mm)
Semicircular	Square	130.1	12.4
C4 airfoil	Square	130.0	12.2
Semicircular	C4 airfoil	130.0	12.3

The Reynolds number was $\sim 1 \times 10^4$ in the water tunnel. Experiments were conducted at atmospheric temperature and pressure conditions, which were approximately 22°C and 101 kPa.

Results of Low-Level Flow-Induced Sound Experiments

The results obtained in the open-circuit air tunnel, for the plate with a semicircular leading edge and a square thick trailing edge, are shown in Fig. 14. These results include the variation with flow velocity of the vortex shedding frequency from the trailing edge, the SPL at the vortex shedding frequency, and the SPL at the β -mode acoustic resonant frequency ($f_\beta \approx 614$ Hz). Although it is not shown in Fig. 14, when the flow velocity reached approximately 30 m/s the vortex shedding frequency was approximately equal to the β -mode resonant frequency and locked shedding occurred. Loud resonant sound was excited, as described earlier. However, when the flow velocity was increased from 6 to 15 m/s, peaks in the SPL at the β -mode acoustic resonant frequency ($f_\beta \approx 614$ Hz) were recorded and are highlighted in Fig. 14. These peaks ranged from 70 to 95 dB ($0.0001 \leq u'/U \leq 0.002$). At a flow velocity corresponding to a peak (eg, 10.8 m/s at 92 dB), the vortex shedding frequency f at the trailing edge of the plate was 190 Hz, which was much less than the resonant acoustic frequency f_β and was therefore not locked. On further

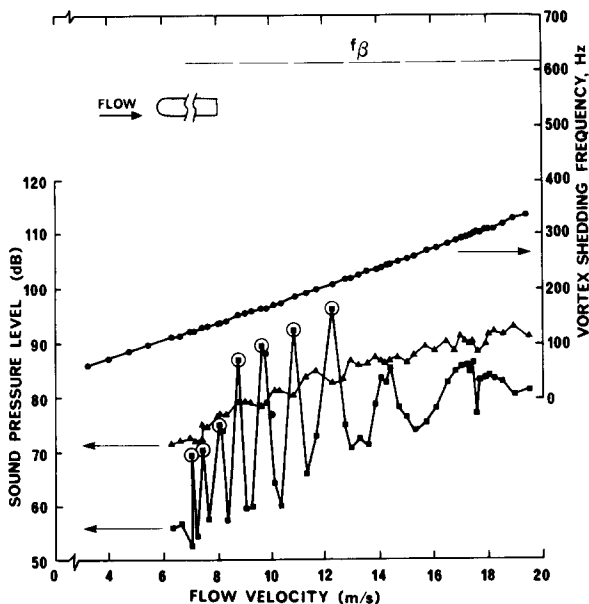

Figure 14. Plot showing the excitation of sound by flow around a plate with a semicircular leading edge and a square thick trailing edge. (●), Vortex shedding frequency; (■), SPL of resonant β -mode acoustic frequency; (▲), SPL at vortex shedding frequency; (---) β -mode resonant frequency; (○) peak in SPL at β -mode resonant frequency.

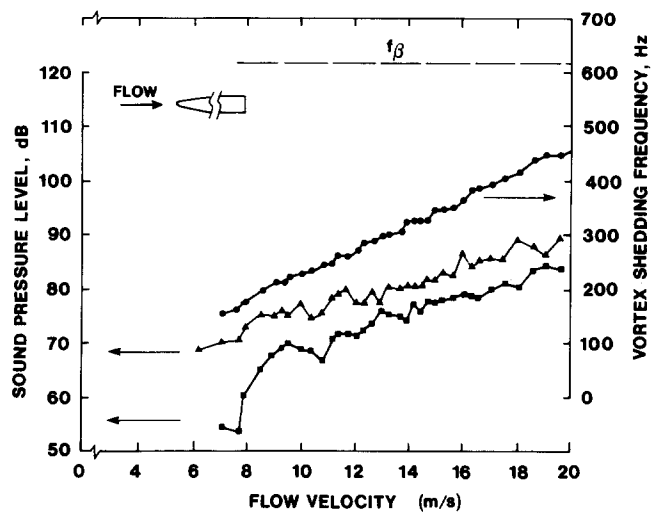

Figure 15. Plot showing the excitation of sound by flow around a plate with an airfoil leading edge and a square thick trailing edge. (●) Vortex shedding frequency; (■) SPL at resonant β -mode acoustic frequency; (▲) SPL at vortex shedding frequency; (---) β -mode resonant frequency.

inspection, the vortex shedding frequencies in the wake, when the peaks in the SPL at the β -mode frequency (ie, additional β -mode resonances) were excited, were not simple subharmonics of the acoustic resonant frequency (f_β).

The SPL at the frequency of the vortex shedding from the trailing edge of the plate was also measured and is shown in Fig. 14. It generally increased with flow velocity and did not have the sharp peaks observed in the SPL at the β -mode resonant frequency.

Flow around the plate with the airfoil leading edge and square thick trailing edge located in the working section generated a vortex street from the trailing edge similar to that for the plate with a semicircular leading edge described above. A similar locked vortex shedding regime with β -mode resonant sound (614 Hz) was generated at flow velocities of approximately 30 m/s. However, the additional β -mode resonances at lower flow velocities, between 6 and 15 m/s, which were observed for the plate with a semicircular edge, were not observed for this plate with an airfoil leading edge (Fig. 15). When the flow velocity was increased from zero up to 20 m/s, the SPLs at both the resonant acoustic β -mode frequency and the vortex shedding frequency increased without any significant local peaks occurring.

Flow around the remaining plate, with a semicircular leading edge and an airfoil trailing edge, did not produce a natural Strouhal vortex street shed from the trailing edge in the absence of resonant sound in the Reynolds number range up to 2×10^5 . However, it did excite β -mode acoustic resonances at approximately 622 Hz over many ranges of flow velocity (Fig. 16). When these resonances were excited at flow velocities greater than 10 m/s, vortices were shed from the trailing edge at a frequency locked to the resonant β -mode acoustic frequency.

In summary, flow around the plate with the semicircular leading edge and square thick trailing edge generated a series of β -mode resonances at approximately 614 Hz. These resonances occurred at flow velocities less than the velocity at which the vortex shedding frequency in the wake was equal

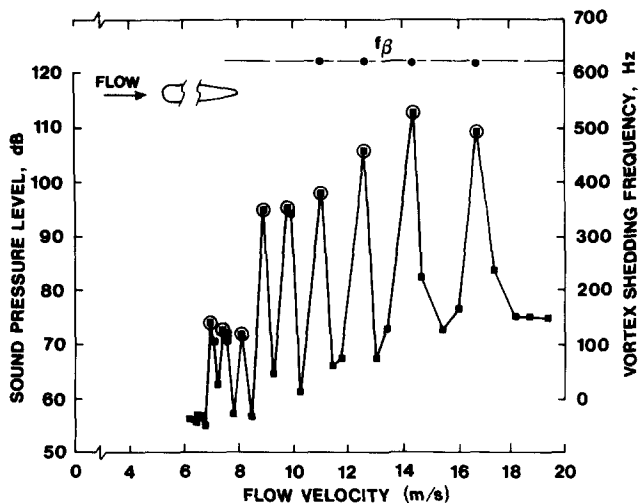

Figure 16. Plot showing the excitation of sound by flow around a plate with a semicircular leading edge and an airfoil trailing edge. (●) Vortex shedding frequency; (■) SPL at resonant β -mode acoustic frequency; (---) β -mode resonant frequency; (○) peak in SPL at β -mode frequency.

to the β -mode resonant acoustic frequency. They were therefore excited when the vortex shedding frequency in the wake downstream of the trailing edge of the plate was less than the frequency of the resonant sound being excited. There was no apparent relationship between the vortex shedding frequency in the wake downstream of the trailing edge and the resonant acoustic frequency when the additional resonances were excited, and the vortex shedding frequency was not a subharmonic of the resonant sound frequency.

Flow around the plate with an airfoil leading edge and a square thick trailing edge generated a β -mode resonance at 614 Hz with vortex shedding from the trailing edge locked to the resonant acoustic field at a flow velocity of approximately 30 m/s. However, in this case the flow did not generate any additional β -mode resonances at lower flow velocities. The flow around the remaining plate with a semicircular leading edge and an airfoil trailing edge did not shed a natural Strouhal vortex street in the absence of resonant sound but did excite β -mode resonances at 622 Hz over many ranges of flow velocity. When the resonant sound was generated, a vortex street was shed from the trailing edge with the vortex shedding frequency locked to the acoustic resonant frequency.

Hypotheses Describing the Source of the Additional β -Mode Acoustic Resonances and the Feedback Effect of the Sound on the Boundary Layers

The following hypothesis provides an explanation of the mechanism for the production of the additional β -mode acoustic resonances generated by flow-sound interaction. For the plate with the semicircular leading edge and square thick trailing edge, it is hypothesized that the additional β -mode resonances are excited by vortices shedding into the plate boundary layers from the small leading edge separation bubbles that exist on each side of the plate [48]. These vortices are shed regularly due to the feedback effect of the sound on the shear layers at the leading edge of the plate in the manner described by Welsh and Gibson [28] and Stokes and Welsh [46] for plates with square leading edges. The vortices are shed at the sound

frequency and traverse the plate to the trailing edge, where they generate resonant sound before merging with the larger vortices in the vortex street downstream of the plate.

This hypothesis is supported by the results described above for the plate with the airfoil leading edge and square thick trailing edge. With this plate installed, the flow excited only the conventional β -mode resonance with locked vortex shedding from the trailing edge. No additional β -mode resonances were excited at other flow velocities, which is consistent with the hypothesis since there are no separation bubbles near the leading edge [48]. The flow around the leading edge is laminar and does not separate from the plate surface. Consequently the sound does not feed back onto the flow upstream of the trailing edge and cause vortices to shed regularly into the boundary layers at the sound frequency to excite the resonant sound. The results for the plate with the semicircular leading edge and airfoil trailing edge also support the hypothesis. Since there are separation bubbles associated with the semicircular leading edge, the sound can feed back onto the associated shear layers and generate vortices that in turn excite the β -mode resonant sound over many flow velocity ranges.

Further Experimental Results to Support the Hypothesis

In an attempt to verify the existence of the vortices being shed from the leading edge of the plates, the coherence of the hot-wire and probe microphone signals, when both are located in the midchord plane, was recorded. The results are shown in Figs. 17-19. The midchord plane was chosen as the measuring plane since the acoustic particle velocities for the β mode are extremely small at this location and cannot be detected by a conventional hot-wire anemometer. Consequently, any velocity component measured by the hot wire at the β -mode resonant sound frequency must be due to the flow and not the acoustic particle velocity associated with the resonant acoustic β mode. Furthermore, the acoustic pressures due to the β mode are a maximum in the midchord plane (Fig. 1), and therefore the signal-to-noise ratio for the probe microphone is also greatest when it is located in this plane.

For the plate with a semicircular leading edge and square thick trailing edge (Fig. 17), the coherence between the probe

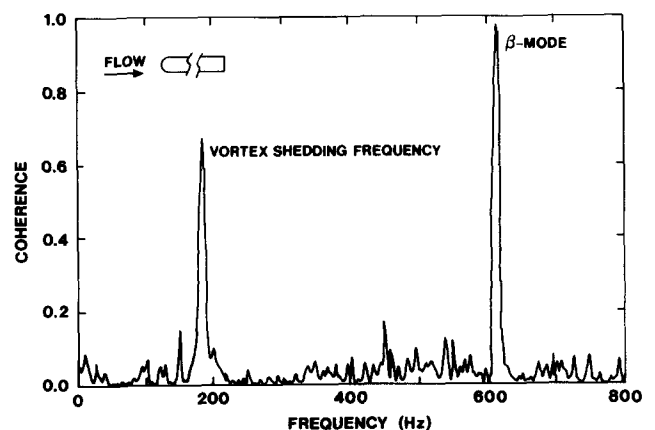

Figure 17. Coherence between the probe microphone and hot-wire sensor in the midchord plane of a plate with a semicircular leading edge and a square thick trailing edge; $U = 10.8$ m/s; SPL = 92 dB.

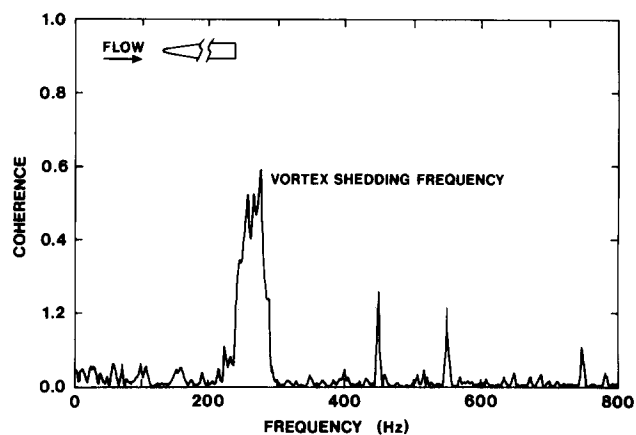

Figure 18. Coherence between the probe microphone and hot-wire sensor in the midchord plane of a plate with an airfoil leading edge and a square thick trailing edge; $U = 11.8$ m/s; SPL = 72 dB.

microphone and the hot-wire signals shows marked peaks at both the resonant acoustic β mode and vortex shedding frequencies. The coherence is 0.98 at the resonant acoustic frequency, which is consistent with the hypothesis that vortices are located in the boundary layer and pass by the hot-wire sensor at the acoustic frequency. For a coherence of 0.98 the vortices must maintain a constant phase relationship with the acoustic pressure oscillation detected by the probe microphone.

The coherence between the probe microphone and hot-wire signals for a plate with an airfoil leading edge and square thick trailing edge (Fig. 18) is insignificant at the resonant acoustic frequency (614 Hz), indicating that vortices are not passing the hot-wire sensor at regular intervals at this frequency. This result, together with the observation that additional resonant β modes were not excited for this geometry, is consistent with the hypothesis describing the feedback effect of the sound on the boundary layers.

For the remaining plate with the semicircular leading edge and airfoil trailing edge, the coherence at the resonant acoustic frequency is 0.99 (Fig. 19). This again suggests that vortices are passing the hot-wire sensor at the resonant acoustic fre-

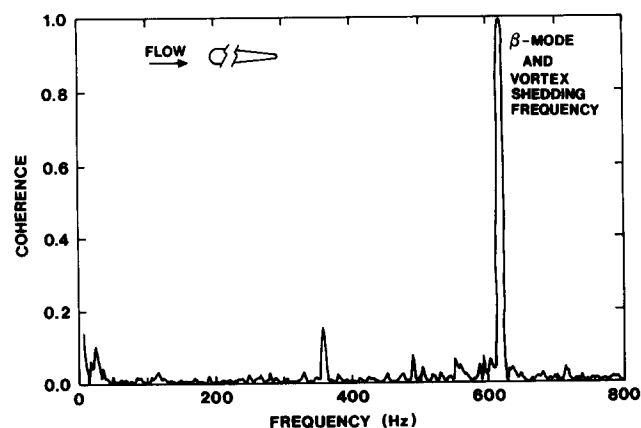

Figure 19. Coherence between the probe microphone and hot-wire sensor in the midchord plane of a plate with a semicircular leading edge and an airfoil trailing edge; $U = 14.3$ m/s; SPL = 111 dB.

quency while maintaining a constant phase relationship with the acoustic pressure field.

In summary, these results support the hypothesis that when additional β -mode resonances are excited they are generated by vortices being shed from the leading edge separation bubbles on the plates. The shear layers near the leading edge respond to feedback of the sound and produce vortices at the sound frequency that in turn generate acoustic power as they pass the trailing edge.

Visualization of the Flows Around the Plates with Simulated Acoustic Feedback

The flows recorded above were simulated by locating each plate in the working section of the water tunnel. A transverse velocity perturbation was superimposed onto the flow around each plate by oscillating the side walls to simulate the perturbation imposed on the flow by the resonant acoustic β mode. The frequency of the perturbation was chosen to give a Strouhal number matching the acoustic Strouhal number recorded in the air tunnel when a resonance was excited. The amplitude of the perturbation was chosen to give a perturbation velocity ratio ($u'/U = 0.03$) that is equivalent to an SPL in the wind tunnel of 120 dB at 10.8 m/s.

Photographs of the flow around the plate with a semicircular leading edge and a square thick trailing edge with and without a perturbation imposed are shown in Fig. 20. Vortices are clearly seen being shed into the boundary layers without and with a transverse velocity perturbation applied by oscillating the side walls. However, with a perturbation imposed, the mean lengths of the leading edge separation bubbles shorten and vortices are shed once each acoustic cycle to produce chains of vortices distributed regularly along the surfaces of the plate. This process is analogous to that observed for plates with square leading edges surrounded by a transverse acoustic field [22, 46]. The influence of the perturbation on the flow in the spanwise direction is also shown in Fig. 20. With a perturbation applied, the vortex tubes are clearly more two-dimensional when they are shed from the leading edge separation bubble than without a perturbation. Further downstream, the hairpin vortices are distributed in a more regular manner on the surface of the plate when a perturbation is applied. The flow around the plate with a semicircular leading edge was also observed with perturbation levels u'/U much less than 0.03. These lower perturbation levels were observed to cause changes in the flow similar to those observed with the higher perturbation level.

Analogous photographs (Fig. 21) of the flow around the plate with an airfoil leading edge and square thick trailing edge show no sign of vortices being shed from near the leading edge with or without the same perturbation as that applied for the plate with a semicircular leading edge ($u'/U = 0.03$).

Although the perturbation velocity ratio for the photographs in Figs. 20 and 21 is higher in the water tunnel than that observed in the air tunnel, these results provide further evidence to support the hypothesis that sound can feed back onto separated shear layers of plates with leading edge separation bubbles and generate the *regular* shedding of almost two-dimensional vortices upstream of the trailing edge of a plate at the sound frequency. Even with this high perturbation velocity ratio, the plate without leading edge separation bubbles (airfoil leading edge) did not have vortices generated in

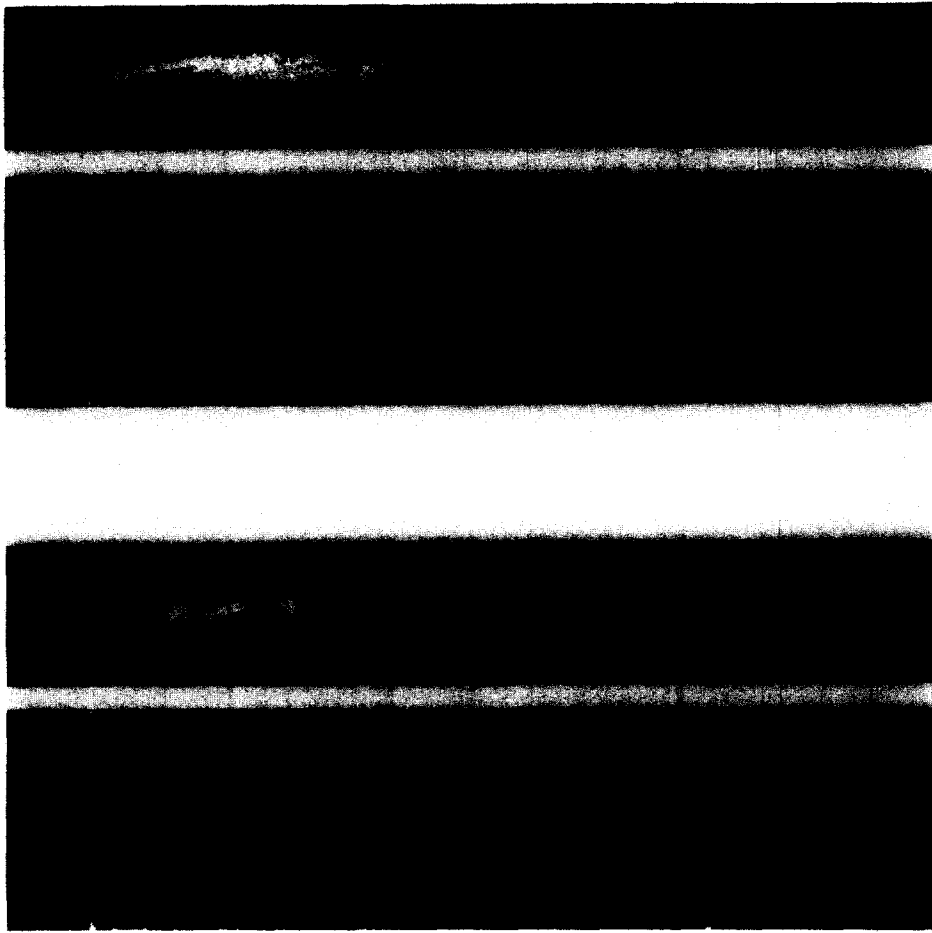

Figure 20. Photographs of flow around a plate with a semicircular leading and square thick trailing edge in the water tunnel (a) with no perturbation, $U = 93.6$ mm/s; and (b) with perturbation. Transverse perturbation frequency, 5.2 Hz; peak-to-peak transverse wall displacement, 0.05 mm; $U = 93.6$ mm/s (equivalent to 10.8 m/s and 614 Hz on Fig. 14).

the boundary layers, and it was this plate that did not generate the additional β -mode resonances described earlier.

IMPLICATIONS FOR AERODYNAMIC DRAG AND HEAT TRANSFER WITH FLOW STRUCTURE CHANGED BY THE FEEDBACK OF SOUND

The presence of a transverse sound field on the flow around a plate with square leading and trailing edges has been found previously [46, 25] to lead to a reduction in the mean length of the leading edge separation bubbles and the regular alternate shedding of vortices from the bubbles on each side of the plate into the boundary layers. Furthermore, significant increases, of comparable magnitude, in both the aerodynamic drag coefficient and the heat transfer coefficient at the plate surface were found to result from a shortening of the leading edge separation bubbles and the regular distribution of vortices in the boundary layers [25, 46].

The effect of sound on plates with semicircular leading edges is also a reduction in the mean length of the leading edge separation bubbles and the regular shedding of vortices into the boundary layers even for sound as low as 70 dB ($u'/U \approx 0.0001$). It is therefore most likely that the analogous heat transfer and aerodynamic drag coefficients of plates

with semicircular leading edges located in a hard-walled wind tunnel will be increased by flow-induced sound as low as 70 dB ($u'/U \approx 0.0001$). Clearly, as shown by flows around the plates in the water tunnel, low-level sound modifies the distribution of vorticity near the surface of the plate.

NUMERICAL SIMULATION OF THE FEEDBACK PROCESS

Experience at the CSIRO has shown that it is possible to predict the influence of feedback on the flow. At low Mach numbers, the oscillating acoustic particle velocities, which are calculated from solutions of the Helmholtz equation, can be superimposed on the flow model to predict the influence of feedback. The effect of the flow velocity on the acoustic field is small at low Mach numbers, and the finite-element solution of the Helmholtz equation provides an accurate prediction of the resonant mode, which is difficult to measure experimentally. The flow model is developed using discrete vortex and surface velocity methods which take advantage of the feedback effect of the two-dimensional acoustic fields generating near two-dimensional flows. The approach used has been to assume the presence of a resonant field, predict the flow and calculate the net acoustic power output, and verify if the resonant field



Figure 21. Photographs of flow around a plate with an airfoil leading edge and a square thick trailing edge in the water tunnel (a) with no perturbation, $U = 93.6$ mm/s; and (b) with perturbation. Transverse perturbation frequency, 5.2 Hz; peak-to-peak transverse wall displacement, 0.05 mm; $U = 93.6$ mm/s (equivalent to 10.8 m/s and 614 Hz on Fig. 15).

could be sustained by predicted sources [46, 36]. Currently, models are being developed that will investigate the acoustic power output of flows with no resonant acoustic field present.

PREVENTION OF ACOUSTIC RESONANCES IN WIND TUNNELS AND TEST RIGS

The prevention of transverse acoustic resonances, which can exist because of the hard walls of the working section in wind tunnels and test rigs, is extremely difficult. However, the first step in their prevention is to ascertain the location of the acoustic source(s) [35, 36, 46] and the origin of the vortices generating the sound. In some circumstances, it may be possible to reshape the geometry at the source region so that sources will cancel each other as described by Stoneman et al [36]. An alternative approach is to alter the geometry where the vortices are originating, for example, to prevent separation bubbles from occurring. A third approach to the suppression of transverse acoustic resonant modes in a wind tunnel is to use active attenuation, where sound is introduced into the working section, which will cancel the sound being generated by the flow. This active control approach is very promising, since it can be designed to cancel sound at a range of acoustic frequencies

and the components of the system are relatively inexpensive. Active attenuation was recently demonstrated by Sunyach and Ffowcs Williams [49] to cancel a flow-induced resonant sound in a Helmholtz resonator. The more general case of the active attenuation of sound in ducts has been examined in detail at the CSIRO by Shepherd et al [50].

TECHNOLOGICAL APPLICATIONS OF THESE RESULTS

Two of the technological areas in which the results of the above experiments are being applied at the CSIRO are:

1. The determination of the aerodynamic acoustic sources in fans and heat exchangers with a view to designing equipment so that the acoustic sources will cancel and lead to a reduction of the unwanted noise
2. The study of the instantaneous forced convection process with a view to augmenting heat transfer in cross-flow heat exchangers with a minimum increase in pressure loss

RECOMMENDATIONS

As a consequence of the feedback process, for relatively low SPLs (as low as 70 dB in the present experiments, where

Table 2. Summary of Experimental Methods Covered in the Text, with Experimental Uncertainties

<i>Experimental Method</i>	<i>Measured Property or Quantity</i>	<i>Experimental Uncertainty Comments (95% Confidence Limit)</i>
Pitot-static tube	Freestream air flow velocity	$\pm 1.4\%$
Tracer timed to travel a given distance	Freestream water tunnel velocity	$\pm 1.5\%$
Narrowband analysis	Acoustic resonant frequency	≤ 1.6 Hz
	Vortex shedding frequency	≤ 1.6 Hz
Piston phone and narrowband analysis	Acoustic pressure levels at the resonant sound and vortex shedding frequencies	
	50 dB < SPL < 60 dB	≤ 2.5 dB
	SPL ≥ 60 dB	≤ 1.0 dB

the ratio of the perturbation velocity to the freestream velocity is approximately 0.0001), there is a need to pay careful attention to the possibility that the acoustics of the wind tunnel play an important role in changing the flow behavior observed around test bodies located in the working section. A microphone should *always* be included in the instrumentation used in wind tunnels, and the spectra of the microphone signal should always be examined. The acoustics of the working section should be examined thoroughly with the test models installed and the tunnel operating.

CONCLUSIONS

Noise at the frequencies of resonant acoustic transverse modes in wind tunnels is naturally amplified relative to the background noise and can feed back onto regions of separated flow surrounding a test model. The feedback process can cause separation bubbles to shorten and vortices to shed regularly into the boundary layers. The development of hairpin vortices in the boundary layers is delayed when the flow is perturbed by resonant sound. By analogy with flows around plates with square leading edges, it is likely that the shortening of the separation bubbles is associated with an increase in the overall heat transfer and aerodynamic drag coefficients. Experimental results at the CSIRO indicate that resonant sound as low as 70 dB (where the ratio of the perturbation velocity due to the sound to the freestream flow velocity is ~ 0.0001) can have this effect.

At these low sound levels, experimenters can be totally unaware of the resonant sound field and its feedback effect on the flow. Therefore, the acoustics of the working section of wind tunnels should be thoroughly examined with the test models installed and the tunnel operating before recording results.

Active attenuation is a very promising and inexpensive method for preventing flow-induced acoustic resonances in wind tunnels.

The uncertainty estimates (to 95% confidence limits) for the experiments described in this paper are given in Table 2.

We wish to thank Mr. N. B. Hamilton for photographing the flows described in the paper and Mr. S. G. Koh for his careful experimental work.

NOMENCLATURE

c chord of the plate (see Fig. 7), m
 d maximum thickness of plate, m
 P_{rms} root-mean square acoustic pressure fluctuations, Pa/3.125 Hz

f vortex shedding frequency, Hz
 f_a applied acoustic frequency, Hz
 f_β β -mode acoustic resonant frequency, Hz
 Re Reynolds number ($= \rho U c / \mu$), dimensionless
 SPL sound pressure level ($= 20 \log(P_{\text{rms}}/20 \mu\text{Pa})$, dB
 St Strouhal number ($= f d / U$, $f_a d / U$, or $f_\beta d / U$), dimensionless
 U freestream flow velocity, m/s
 u' velocity perturbation due to sound, m/s

Greek Symbols

ρ fluid density, kg/m³
 μ fluid viscosity, Pa · s

REFERENCES

1. Leconte, J., On the Influence of Musical Sounds on the Flame of a Jet of Coal-Gas, *Phil. Mag.*, **15**, 235-239, 1858.
2. Tyndall, J., On Sounding and Sensitive Flames, *Phil. Mag.*, **33**, 92-99, 1867.
3. Rayleigh, J. W. S., *The Theory of Sound*, Dover, New York, 1945.
4. Batchelor, G. K., Sound in Wind Tunnels, Australian Council for Aeronautics, Report ACA-18, June 1945.
5. Batchelor, G. K., and Townsend, A. A., Singing Corner Vanes: A Note on a Peculiar Double Resonant Sustained Oscillation Occurring in a Wind Tunnel, Council for Scientific and Industrial Research, Division of Aerodynamics, Note 62, 1945.
6. Parker, R., Resonance in Wake Shedding from Parallel Plates: Some Experimental Observations, *J. Sound Vib.*, **4**, 62-72, 1966.
7. Parker, R., Resonance Effects in Wake Shedding from Parallel Plates: Calculation of Resonant Frequencies, *J. Sound Vib.*, **5**, 332-343, 1967.
8. Bechert, D. W., Excitation of Instability Waves, Proc. IUTAM Symposium on Aero- and Hydro-Acoustics, Lyon, France, pp. 373-384, July 1985.
9. Kline, S. J., Reynolds, W. D., Schraub, F. A., and Runstadler, P. W., The Structure of Turbulent Boundary Layers, *J. Fluid Mech.*, **30**, 741-773, 1967.
10. Roshko, A., Structure of Turbulent Flows: A New Look, *AIAA J.*, **14**, 1349-1357, 1976.
11. Ho, C. M., and Huerre, P., Perturbed Free Shear Layers, *Ann. Rev. Fluid Mech.*, **16**, 365-424, 1984.
12. Brown, G. L., and Roshko, A., On the Density Effects and Large Structure in Turbulent Mixing Layers, *J. Fluid Mech.*, **64**, 775-816, 1974.
13. Perry, A. E., Lim, T. T., and Chong, M. S., The Instantaneous Velocity Fields of Coherent Structures in Coflowing Jets and Wakes, *J. Fluid Mech.*, **101**, 243-256, 1980.
14. Perry, A. E., and Chong, M. S., On the Mechanism of Wall Turbulence, *J. Fluid Mech.*, **119**, 173-197, 1982.

15. Hussain, A. K. M. F., Coherent Structures and Turbulence, *J. Fluid Mech.*, **173**, 303–356, 1986.
16. Hussain, A. K. M. F., and Zaman, K. B. M. Q., Vortex Pairing in a Circular Jet Under Controlled Excitation. Part 2. Coherent Structure Dynamics, *J. Fluid Mech.*, **101**, 493–544, 1980.
17. Hussain, A. K. M. F., and Zaman, K. B. M. Q., The Preferred Mode of the Axisymmetric Jet, *J. Fluid Mech.*, **138**, 39–71, 1981.
18. Zaman, K. B. M. Q., and Hussain, A. K. M. F., Natural Large-Scale Structures in the Axisymmetric Mixing Layer, *J. Fluid Mech.*, **138**, 325–351, 1984.
19. Peterka, J. A., and Richardson, P. D., Effects of Sound on Separated Flows, *J. Fluid Mech.*, **37**, 265–287, 1969.
20. Archibald, F. S., Self-Excitation of Acoustic Resonances by Vortex Shedding, *J. Sound Vib.*, **38**, 81–103, 1975.
21. Bhattacharjee, S., Scheelke, B., and Troutt, T. R., Modification of Vortex Interactions in a Reattaching Separated Flow, *AIAA J.*, **24**, 623–629, 1986.
22. Parker, R., and Welsh, M. C., Effects of Sound on Flow Separation from Blunt Flat Plates, *Int. J. Heat Fluid Flow*, **4**, 113–127, 1983.
23. Cherry, N. J., Hillier R., and Latour, M. E. M. P., Unsteady Measurements in a Separating and Reattaching Flow, *J. Fluid Mech.*, **144**, 13–46, 1984.
24. Kiya, M., and Sasaki, K., Structure of Large-Scale Vortices and Unsteady Reverse Flow in the Reattaching Zone of a Turbulent Separation Bubble, *J. Fluid Mech.*, **92**, 1–16, 1979.
25. Cooper, P. I., Sheridan, J. C., and Flood, G. J., The Effects of Sound on Forced Convection Over a Flat Plate, *Int. J. Heat Fluid Flow*, **7**, 61–68, 1986.
26. Hourigan, K., Welch, L. W., Cooper, P. I., Thompson, M. C., and Welsh, M. C., Organized Vortex and Thermal Structures in a Forced Convection Reattaching Separated Flow, Proc. 2nd ASME/JSME Thermal Engineering Joint Conference, Hawaii, Vol. 5, pp. 195–202, March 1987.
27. Howe, M. S., Contributions to the Theory of Aerodynamic Sound, with Application to Excess Jet Noise and the Theory of the Flute, *J. Fluid Mech.*, **71**, 625–673, 1975.
28. Welsh, M. C., and Gibson, D. C., Interaction of Induced Sound with Flow Past a Square Leading Edged Plate in a Duct, *J. Sound Vib.*, **67**, 501–511, 1979.
29. Nomoto, H., and Culick, E. C., An Experimental Investigation of Pure Tone Generation by Vortex Shedding in a Duct, *J. Sound Vib.*, **84**, 247–252, 1982.
30. Weihs, D., Semi-infinite Vortex Trails, and their Relation to Oscillating Aerofoils, *J. Fluid Mech.*, **54**, 679–690, 1972.
31. Nelson, P. A., Halliwell, N. A., and Doak, P. E., Fluid Dynamics of a Flow Excited Resonance. Part I. Experiment, *J. Sound Vib.*, **78**, 15–38, 1981.
32. Kawahashi, M., Brocher, E., and Collini, P., Coupling of Vortex Shedding with a Cavity, Proc. IUTAM Symposium on Fundamental Aspects of Vortex Motion, Tokyo, Japan, pp. 188–191, 1987.
33. Parker, R., and Stoneman, S. A. T., An Experimental Investigation of the Generation and Consequences of Acoustic Waves in an Axial-Flow Compressor: Large Axial Spacings Between Blade Rows, *J. Sound Vib.*, **99**, 169–182, 1985.
34. Parker, R., and Stoneman, S. A. T., An Experimental Investigation of the Generation and Consequences of Acoustic Waves in an Axial-Flow Compressor: The Effect of Variations in the Axial Spacing Between Blade Rows, *J. Sound Vib.*, **116**, 509–525, 1987.
35. Welsh, M. C., Stokes, A. N., and Parker, R., Flow-Resonant Sound Interaction in a Duct Containing a Plate. Part I. Semicircular Leading Edge, *J. Sound Vib.*, **95**, 305–323, 1984.
36. Stoneman, S. A. T., Hourigan, K., Stokes, A. N., and Welsh, M. C., Resonant Sound Caused by Flow Past Two Plates in Tandem in a Duct, *J. Fluid Mech.*, **192**, 455–484, 1988.
37. Rockwell, D., Oscillations of Impinging Shear Layers, Invited Lecture, 20th Aerospace Sciences Meeting, AIAA-82-0047, 1982.
38. Rockwell, D., and Naudascher, E., Self-Sustained Oscillations of Impinging Free Shear Layers, *Ann. Rev. Fluid Mech.*, **11**, 67–94, 1979.
39. Johnson, C. O., and Loehrke, R. I., An Experimental Investigation of Wake Edge Tones, *AIAA J.*, **22**, 1249–1253, 1984.
40. Mochizuki, O., Kiya, M., and Tazumi, M., Vortex-Body Interaction in a Jet-Circular Cylinder Sound Generation System, Proc. IUTAM Symposium on Fundamental Aspects of Vortex Motion, Tokyo, Japan, pp. 192–195, August–September 1987.
41. Loehrke, R. I., and Nagib, H. M., Experiments on Management of Freestream Turbulence, AGARD Report, R-598, AD-749-891, 1972.
42. Loehrke, R. I., and Nagib, H. M., Control of Free-Stream Turbulence by means of Honeycombs: A Balance Between Suppression and Generation, *ASME, J. Fluids Eng.*, **98**, 342–353, 1976.
43. Bassett, R. W., and Fowler, H. S., Improvements to Smoke Generator for Use in Wind Tunnels, National Research Council of Canada, Report 12288, 1971.
44. Clayton, B. R., and Massey, B. S., Flow Visualization in Water: A Review of Techniques, *J. Sci. Instrum.*, **44**, 2–11, 1967.
45. Schraub, F. A., Kline, S. J., Henry, J., Runstadler, P. W., and Littell, A., Use of Hydrogen Bubbles for Quantitative Determination of Time-Dependent Velocity Fields in Low-Speed Water Flows, *ASME, J. Basic Eng.*, **87**, 429–444, 1965.
46. Stokes, A. N., and Welsh, M. C., Flow-Resonant Sound Interaction in a Duct Containing a Plate. II. Square Leading Edge, *J. Sound Vib.*, **104**, 55–73, 1986.
47. Howell, A. R., Fluid Dynamics of Axial Compressors, Proc. Institute of Mechanical Engineering, p. 153, 1945.
48. Roberts, W. B., The Effects of Reynolds Number and Laminar Separation on Axial Cascades, *ASME, J. Eng. Power*, **97**, 261–274, 1975.
49. Sunyach, M., and Ffowcs Williams, J. E., The Active Suppression of Oscillation in Flow-Excited Cavities, *C.R. Acad. Sci. Paris*, **303**, Ser. II, No. 12, 1986.
50. Shepherd, I. C., La Fontaine, R. F., and Cabelli, A., Active Attenuation in Flow Ducts: Assessment of Potential Applications, Proc. ASME Winter Annual Meeting, Anaheim, Cal., Paper No. 86-WA/NCA-26, December 1986.